

## Thermal Economics Ltd

Thermal House  
8 Cardiff Road  
Luton  
Bedfordshire LU1 1PP  
Tel: 01582 450814 Fax: 01582 429305  
e-mail: info@thermaleconomics.co.uk  
website: www.thermaleconomics.co.uk



Agrément Certificate  
**90/2436**  
Product Sheet 2

### ALREFLEX DRY LINING WALL INSULATION

### ALREFLEX 1L-1 DRY LINING WALL INSULATION

This Agrément Certificate Product Sheet<sup>(1)</sup> relates to Alreflex 1L-1 Dry Lining Wall Insulation, a single-layer polyethylene bubble sheet faced on one side with a coated aluminium foil, for use as part of an insulating dry lining system for masonry walls in existing and new dwellings and buildings of similar occupancy.

(1) Hereinafter referred to as 'Certificate'.

#### CERTIFICATION INCLUDES:

- factors relating to compliance with Building Regulations where applicable
- factors relating to additional non-regulatory information where applicable
- independently verified technical specification
- assessment criteria and technical investigations
- design considerations
- installation guidance
- regular surveillance of production
- formal three-yearly review.

#### KEY FACTORS ASSESSED

**Thermal performance** — the outer foil has an emissivity of 0.03 and the bubble sheet has a thermal resistance of  $0.10 \text{ m}^2 \cdot \text{K} \cdot \text{W}^{-1}$ . The product can contribute to limiting heat loss through walls (see section 6).

**Condensation risk** — the product can contribute to limiting the risk of surface condensation. The risk of interstitial condensation should be assessed in each case (see section 7).

**Behaviour in relation to fire** — the product is classified as Class 1 for reaction to fire and its use does not prejudice the fire resistance properties of the wall (see section 8).

**Durability** — the product will have a life equivalent to that of the wall on which it is installed (see section 11).

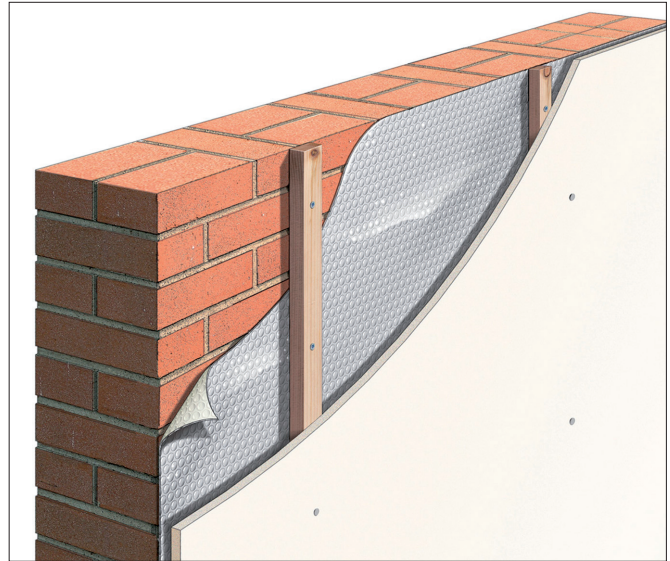

The BBA has awarded this Certificate to the company named above for the product described herein. This product has been assessed by the BBA as being fit for its intended use provided it is installed, used and maintained as set out in this Certificate.

On behalf of the British Board of Agrément

A handwritten signature in black ink, appearing to read 'John Albon'.

Date of First issue: 4 April 2016

John Albon — Head of Approvals  
Construction Products

A handwritten signature in black ink, appearing to read 'Claire Curtis-Thomas'.

Claire Curtis-Thomas  
Chief Executive

Originally certificated on 17 June 1994

*The BBA is a UKAS accredited certification body — Number 113. The schedule of the current scope of accreditation for product certification is available in pdf format via the UKAS link on the BBA website at [www.bbacerts.co.uk](http://www.bbacerts.co.uk)*

*Readers are advised to check the validity and latest issue number of this Agrément Certificate by either referring to the BBA website or contacting the BBA direct.*

British Board of Agrément  
Bucknalls Lane  
Watford  
Herts WD25 9BA

tel: 01923 665300  
fax: 01923 665301  
clientservices@bba.star.co.uk  
[www.bbacerts.co.uk](http://www.bbacerts.co.uk)

©2016

# Regulations

In the opinion of the BBA, Alreflex 1L-1 Dry Lining Wall Insulation, if installed, used and maintained in accordance with this Certificate, can satisfy or contribute to satisfying the relevant requirements of the following Building Regulations (the presence of a UK map indicates that the subject is related to the Building Regulations in the region or regions of the UK depicted):



## The Building Regulations 2010 (England and Wales) (as amended)

<b>Requirement:</b> B2	<b>Internal fire spread (linings)</b>
<b>Comment:</b>	The product is unrestricted under this Requirement. See section 8 of this Certificate.
<b>Requirement:</b> B3(4)	<b>Internal fire spread (structure)</b>
<b>Comment:</b>	The product can contribute to satisfying this Requirement. See section 8 of this Certificate.
<b>Requirement:</b> C2(c)	<b>Resistance to moisture</b>
<b>Comment:</b>	The product can contribute to satisfying this Requirement. See sections 7.1 and 7.3 of this Certificate.
<b>Requirement:</b> L1(a)(i)	<b>Conservation of fuel and power</b>
<b>Comment:</b>	The product can contribute to satisfying this Requirement. See sections 6.1 and 6.3 of this Certificate.
<b>Regulation:</b> 7	<b>Materials and workmanship</b>
<b>Comment:</b>	The product is acceptable. See section 11 and the <i>Installation</i> part of this Certificate.
<b>Regulation:</b> 26	<b>CO<sub>2</sub> emission rates for new buildings</b>
<b>Regulation:</b> 26A	<b>Fabric energy efficiency rates for new dwellings (applicable to England only)</b>
<b>Regulation:</b> 26A	<b>Primary energy consumption rates for new buildings (applicable to Wales only)</b>
<b>Regulation:</b> 26B	<b>Fabric performance values for new dwellings (applicable to Wales only)</b>
<b>Comment:</b>	The product can contribute to satisfying these Regulations although compensating fabric and/or services measures will need to be taken. See sections 6.1 and 6.3 of this Certificate.



## The Building (Scotland) Regulations 2004 (as amended)

<b>Regulation:</b> 8(1)	<b>Durability, workmanship and fitness of materials</b>
<b>Comment:</b>	The product is acceptable. See section 11 and the <i>Installation</i> part of this Certificate.
<b>Regulation:</b> 9	<b>Building standards applicable to construction</b>
<b>Standard:</b> 2.5	<b>Internal linings</b>
<b>Comment:</b>	The product is unrestricted under this Standard, with reference to clause 2.5.1 <sup>(1)</sup> . See section 8 of this Certificate.
<b>Standard:</b> 3.15	<b>Condensation</b>
<b>Comment:</b>	The product can contribute to satisfying this Standard, with reference to clauses 3.15.1 <sup>(1)(2)</sup> , 3.15.4 <sup>(1)(2)</sup> and 3.15.5 <sup>(1)(2)</sup> . See sections 7.2 and 7.3 of this Certificate.
<b>Standard:</b> 6.1(b)	<b>Carbon dioxide emissions</b>
<b>Standard:</b> 6.2	<b>Building insulation envelope</b>
<b>Comment:</b>	The product can contribute to satisfying clauses (or parts of) 6.1.1 <sup>(1)</sup> , 6.1.2 <sup>(2)</sup> , 6.1.4 <sup>(2)</sup> , 6.1.6 <sup>(1)</sup> , 6.2.1 <sup>(1)(2)</sup> , 6.2.3 <sup>(1)</sup> , 6.2.4 <sup>(1)</sup> , 6.2.5 <sup>(2)</sup> , 6.2.6 <sup>(1)(2)</sup> , 6.2.7 <sup>(1)</sup> , 6.2.8 <sup>(2)</sup> , 6.2.9 <sup>(1)(2)</sup> , 6.2.10 <sup>(1)</sup> , 6.2.11 <sup>(1)(2)</sup> , 6.2.12 <sup>(2)</sup> and 6.2.13 <sup>(1)(2)</sup> of these Standards, although compensating fabric and/or services measures will need to be taken. See sections 6.1 and 6.3 of this Certificate.
<b>Standard:</b> 7.1(a)(b)	<b>Statement of sustainability</b>
<b>Comment:</b>	The product can contribute to satisfying the relevant requirements of Regulation 9, Standards 1 to 6, and therefore will contribute to a construction meeting a bronze level of sustainability as defined in this Standard. See sections 6.1 and 6.3 of this Certificate.
<b>Regulation:</b> 12	<b>Building standards applicable to conversions</b>
<b>Comment:</b>	All comments given for the product under Regulation 9, Standards 1 to 6, also apply to this Regulation, with reference to clause 0.12.1 <sup>(1)</sup> and Schedule 6 <sup>(1)</sup> . (1) Technical Handbook (Domestic). (2) Technical Handbook (Non-Domestic).



## The Building Regulations (Northern Ireland) 2012 (as amended)

<b>Regulation:</b> 23	<b>Fitness of materials and workmanship</b>
<b>Comment:</b>	The product is acceptable. See section 11 and the <i>Installation</i> part of this Certificate.
<b>Regulation:</b> 29	<b>Condensation</b>
<b>Comment:</b>	The product can contribute to satisfying this Regulation. See section 7.3 of this Certificate.
<b>Regulation:</b> 34	<b>Internal fire spread – Linings</b>
<b>Comment:</b>	The product is unrestricted under this Regulation. See section 8 of this Certificate.
<b>Regulation:</b> 35(4)	<b>Internal fire spread – Structure</b>
<b>Comment:</b>	The product can contribute to satisfying this Regulation. See section 8 of this Certificate.
<b>Regulation:</b> 39(a)(i)	<b>Conservation measures</b>
<b>Regulation:</b> 40(2)	<b>Target carbon dioxide emission rate</b>
<b>Comment:</b>	The product can contribute to satisfying these Regulations. See sections 6.1 and 6.3 of this Certificate.

In the opinion of the BBA there is no information in this Certificate which relates to the obligations of the client, Principal Designer/CDM co-ordinator, designer and contractors under these Regulations.

## Additional Information

### NHBC Standards 2016

NHBC accepts the use of Alreflex 1L-1 Dry Lining Wall Insulation, provided it is installed, used and maintained in accordance with this Certificate, in relation to *NHBC Standards, Chapter 9.2 Wall and ceiling finishes*.

## Technical Specification

### 1 Description

1.1 Alreflex 1L-1 Dry Lining Wall Insulation consists of one layer of polyethylene bubble sheet faced on one side with an aluminium foil-lining. The foil is protected by a thin polyethylene film.

1.2 The product is available with the nominal characteristics shown in Table 1.

*Table 1 Nominal characteristics*

Length (m)	25
Width (m)	1.2 and 1.5
Thickness (mm)	3.5 ± 0.5
Weight (g·m <sup>-2</sup> )	165 ± 15

1.3 Ancillary items used, but outside the scope of this Certificate assessment, include:

- Thermal Economics Alu Tape
- preservative-treated timber battens
- galvanized metal furring channels
- nails, screws and plugs
- plasterboard to BS EN 520 : 2004
- double-sided adhesive tape
- gypsum bonding compound.

### 2 Manufacture

2.1 Aluminium foil is laminated to the back of the polyethylene bubble sheet and, at a preset point, a third layer of the low density material is laminated and a flat surface given to both sides.

2.2 As part of the assessment and ongoing surveillance of product quality, the BBA has:

- agreed with the manufacturer the quality control procedures and product testing to be undertaken
- assessed and agreed the quality control operated over batches of incoming materials
- monitored the production process and verified that it is in accordance with the documented process
- evaluated the process for management of nonconformities
- checked that equipment has been properly tested and calibrated
- undertaken to carry out the above measures on a regular basis through a surveillance process, to verify that the specifications and quality control operated by the manufacturer are being maintained.

2.3 The management system of the manufacturer has been assessed and registered as meeting the requirements of BS EN ISO 9001 : 2008 by BSI (Certificate FM 82602).

### 3 Delivery and site handling

3.1 The product is delivered to site in rolls within a protective polythene bag. Each bag carries inserts providing a description of the material and factory production information.

3.2 The product should be stored in clean and dry conditions, off the ground and under cover to protect it from precipitation. Damaged products should be discarded.

# Assessment and Technical Investigations

The following is a summary of the assessment and technical investigations carried out on Alreflex 1L-1 Dry Lining Wall Insulation.

## Design Considerations

### 4 General

4.1 Alreflex 1L-1 Dry Lining Wall Insulation is for use as part of an insulating dry lining system for masonry walls (where masonry includes clay and calcium silicate bricks, concrete blocks, and natural and reconstituted stone blocks) in new and existing dwellings or buildings with similar occupancy. It should be installed in accordance with the Certificate holder's instructions.

4.2 Walls should be designed and constructed in accordance with the relevant recommendations of:

- BS EN 1996-1-1 : 2005, BS EN 1996-1-2 : 2005, BS EN 1996-2 : 2006 and BS EN 1996-3 : 2006 and their respective UK National Annexes
- BS 8000-3 : 2001.

4.3 With dry lining installations that form a void, services can be incorporated behind the dry lining, making chasing of the wall unnecessary. Where possible, penetration of the product by services such as light switches or power outlets should be kept to a minimum.

4.4 The installation of an insulating dry lining system requires careful detailing around doors and windows to achieve a satisfactory surface for finishing. In addition, every attempt should be made to minimise the risk of thermal bridging at reveals and where heavy separating walls are attached to the external wall. New work must be designed to accommodate the thickness of the dry lining, particularly at reveals, heads and sills and in relation to ceiling height. Where the dimensions of fixtures are critical (eg bathrooms), these should be checked before installation.

### 5 Practicability of installation

The product is designed to be installed by a competent general builder, or a contractor experienced with this type of product.

### 6 Thermal performance



6.1 Calculations of thermal transmittance (U value) should be carried out in accordance with BS EN ISO 6946 : 2007 and BRE Report BR 443 : 2006, using the following product data.

- 0.03 outer surface emissivity
- $0.10 \text{ m}^2 \cdot \text{K} \cdot \text{W}^{-1}$  core R value of the bubble sheet
- $0.00 \text{ m}^2 \cdot \text{K} \cdot \text{W}^{-1}$  core R value of the bubble sheet when crushed between battens or between battens and metal furrings
- $0.71 \text{ m}^2 \cdot \text{K} \cdot \text{W}^{-1}$  R value for air cavities ( $\geq 20$  mm thick) adjacent to the product (horizontal heat flow)
- 100% percentage of 1L-1 thickness in adjacent cavity.

6.2 The U value of a complete wall construction will depend on the thickness and conductivity of the additional insulation, fixings used, the thermal properties of the substrate wall, bridging and any finishes. Example U values are given in Table 2. Additional insulation will be required to meet the U values in the national Building Regulations.

Table 2 Example U values

	U value ( $\text{W} \cdot \text{m}^{-2} \cdot \text{K}^{-1}$ )
	215 mm brickwork $\lambda = 0.77 \text{ W} \cdot \text{m}^{-1} \cdot \text{K}^{-1}$ (1)
Timber battens	0.96 <sup>(2)</sup>
Metal furrings	1.1 <sup>(3)</sup>

(1) Brickwork bridged by 17.1% mortar ( $\lambda = 0.88 \text{ W} \cdot \text{m}^{-1} \cdot \text{K}^{-1}$ ).

(2) Product installed on the internal side of 19 mm by 38 mm battens at 400 mm centres (9.5% bridging). 100% of product distributed into the adjacent cavity. Remaining cavity space is 15.5 mm thick with a resistance of  $0.566 \text{ m}^2 \cdot \text{K} \cdot \text{W}^{-1}$ .

(3) Product installed on the internal side of 22 mm metal furrings (assumed to have 1 mm thick steel with 50 mm flanges) attached to the substrate spaced at 400 mm centres, and 100% of product distributed into the adjacent cavity. Remaining cavity space is 18.5 mm thick with a resistance of  $\text{m}^2 \cdot \text{K} \cdot \text{W}^{-1}$ .



6.3 The product can maintain, or contribute to maintaining, continuity of thermal insulation at junctions between elements and openings. For Accredited Construction Details, the corresponding  $\psi$ -values (Psi) in BRE Information Paper IP 1/06, Table 3, may be used in carbon emission calculations in Scotland and Northern Ireland.

Detailed guidance for other junctions and on limiting heat loss by air infiltration can be found in the documents supporting the national Building Regulations.

## 7 Condensation risk

### Surface condensation



7.1 Walls incorporating the product will adequately limit the risk of surface condensation when the thermal transmittance (U value) does not exceed  $0.7 \text{ W}\cdot\text{m}^{-2}\cdot\text{K}^{-1}$  at any point and the junctions with other elements are designed in accordance with section 6.3 of this Certificate. Additional insulation will be required in order for the construction to meet this requirement.



7.2 Walls incorporating the product will adequately limit the risk of surface condensation when the thermal transmittance (U value) does not exceed  $1.2 \text{ W}\cdot\text{m}^{-2}\cdot\text{K}^{-1}$  at any point and the junctions with other elements are designed in accordance with the guidance referred to in BS 5250 : 2011, Annex G. Further guidance may be obtained from BRE Report BR 262 : 2002 and section 6.3 of this Certificate.

### Interstitial condensation



7.3 Walls incorporating the product will adequately limit the risk of interstitial condensation when they are designed and constructed in accordance with BS 5250 : 2011, Annexes D and G, and the relevant guidance.

7.4 The bubble sheet has a nominal vapour resistance exceeding  $125 \text{ MN}\cdot\text{s}\cdot\text{g}^{-1}$  and hence provides a significant resistance to water vapour transmission.

7.5 The use of the product does not preclude the normal precautions against formation of condensation, especially in rooms expected to have high humidities. When the product is installed adjacent to the brickwork, a well-sealed vapour control layer (VCL) will be required on the warm side of the construction in order to limit the amount of moisture reaching the surface of the product unless a calculation, as described in section 7.3, indicates otherwise.

## 8 Behaviour in relation to fire



8.1 The product achieved a Class 1 fire classification when tested on the foil-face to BS 476-7 : 1997.

8.2 When installed with an internal lining board, the product will be contained between the wall and the internal lining board, until one is destroyed. Therefore, the product will not contribute to the development stages of a fire.

## 9 Proximity of flues and appliances

When the product is installed in close proximity to certain flue pipes and/or heat-producing appliances, the relevant provisions of the national Building Regulations are applicable:

**England and Wales** — Approved Document J, paragraph 2.15

**Scotland** — Mandatory Standard 3.19, clauses 3.19.1<sup>(1)</sup>(2) to 3.19.9<sup>(1)</sup>(2)

(1) Technical Handbook (Domestic).

(2) Technical Handbook (Non-Domestic).

**Northern Ireland** — Technical Booklet L, paragraph 3.15.

## 10 Maintenance

As the product is confined within a structure and has suitable durability (see section 11), maintenance is not required.

## 11 Durability



The product is durable, rot-proof, water-resistant and sufficiently stable to remain effective as insulation for the life of the building.

# Installation

## 12 General

12.1 During construction, care must be taken to ensure the product is not damaged during installation. Should damage occur by tearing, the product must be repaired or replaced.

12.2 Joints, overlaps, areas around details and isolated puncture areas must be sealed with Thermal Economics Alu Tape.

12.3 Bearing surfaces for timber battens and metal furrings should comply with BS 8212 : 1995. The depth of timber battens or metal furrings will determine the air space achieved on either side of the product. The thickness of Alreflex 1L-1 must also be considered as part of the design specification to achieve the required air space (see Table 2).

12.4 All insulated dry lining installations require careful planning and setting out.

## 13 Procedure

### Timber batten method

13.1 Preservative-treated timber battens, with a nominal cross-section of 19 mm by 38 mm, are fixed at vertical centres to the wall with suitable fixings, eg wire-cut nails, screws, plugs (see Figures 1 to 5). Centres must be not more than 400 mm and 600 mm for plasterboard thicknesses of 9.5 mm and 12.5 mm or greater, respectively. Adequate time should be allowed for solvent-based preservatives to be fixed and for the solvent to evaporate.

13.2 The product is butt-jointed on the battens with the foil facing the wall, then stapled or fixed with clout nails to the battens and pulled tight to maintain the cavity between it and the wall. The joints are sealed with Thermal Economics Alu Tape.

13.3 The plasterboard is fixed over the Alreflex 1L-1 and onto the battens in the usual manner.

### Metal furrings method

13.4 Galvanized metal furrings are fixed to the wall at vertical centres using dabs of gypsum bonding compound (see Figure 6). The inner face of the metal furring must be a minimum of 20 mm from the wall face and centres must be no more than 400 mm and 600 mm for plasterboard thicknesses of 9.5 mm and 12.5 mm or greater, respectively.

13.5 100 mm lengths (approximately) of double-sided adhesive tape are applied to the metal furrings at 200 mm intervals. The release paper should be temporarily left on the tape to allow for a trial fit and to enable the product to be cut to the required size.

13.6 The release papers are then removed from the tape, and the pre-cut Alreflex 1L-1 is carefully adhered and butt-jointed over the metal furrings. The product must be applied with the foil facing the wall and be sufficiently taut to maintain the cavity between it and the wall. The plasterboard is fixed over the product and secured to the metal furrings using self-tapping screws.

13.7 Finishes, eg skirting or coving, may then be applied in the usual manner

Figure 1 General arrangement

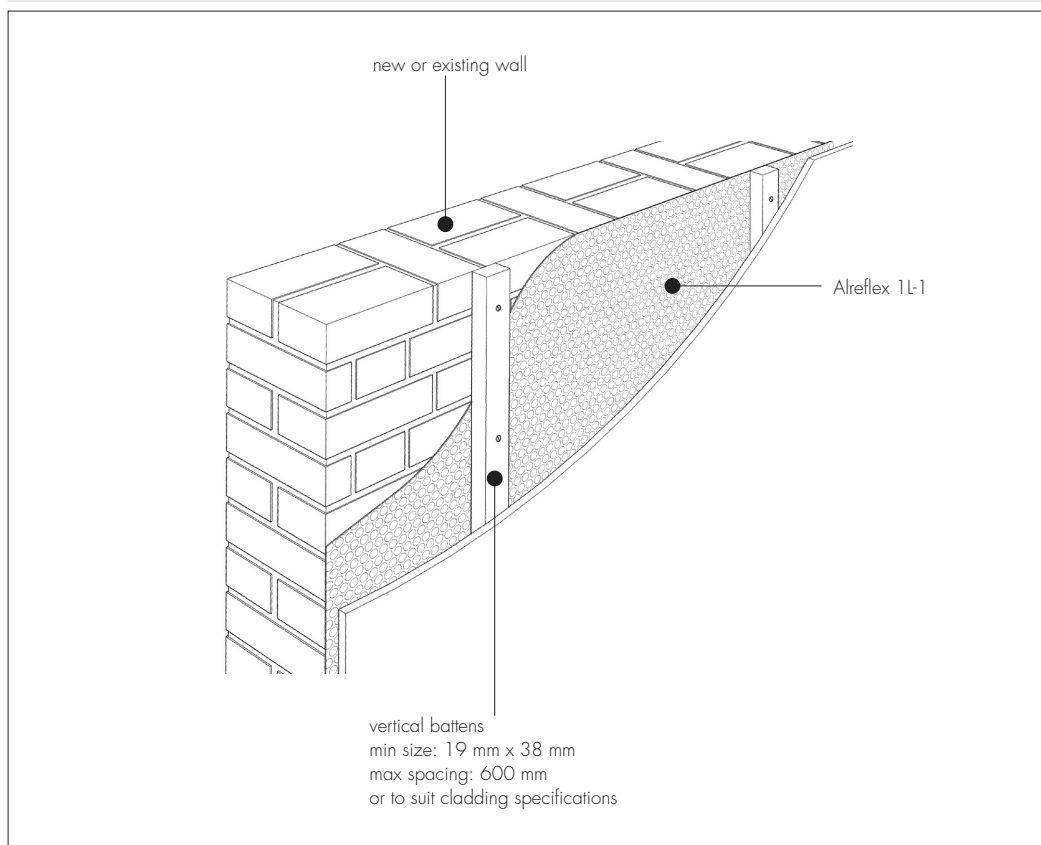

Figure 2 Typical door or window reveal detail

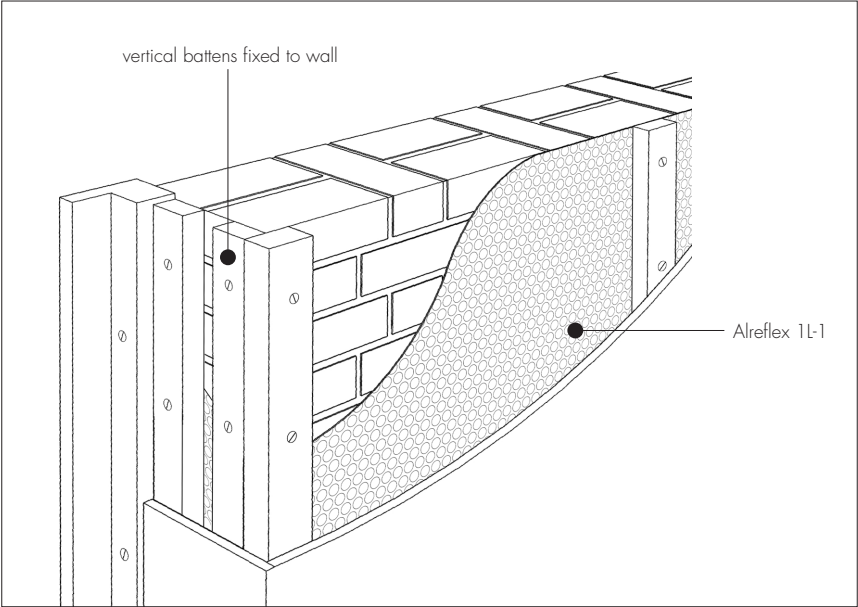

Figure 3 Typical external corner detail

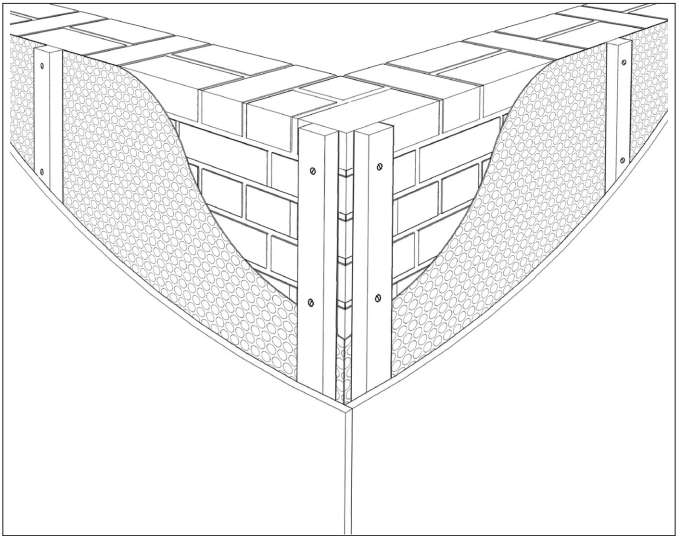

Figure 4 Typical internal corner detail

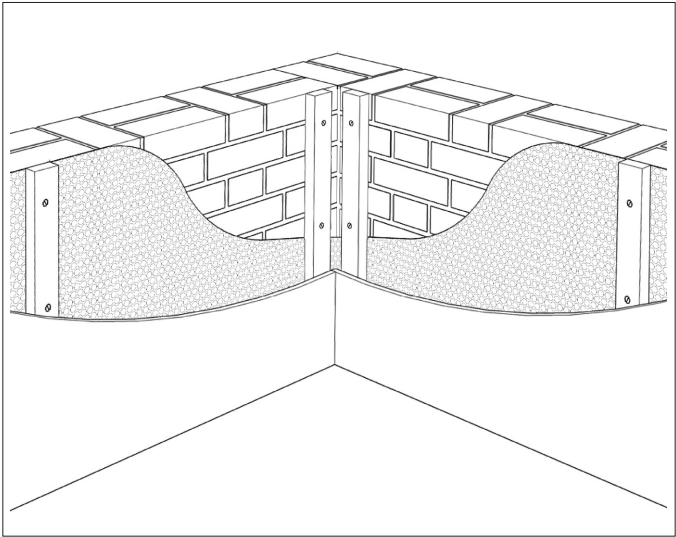

Figure 5 Detail of butt joint

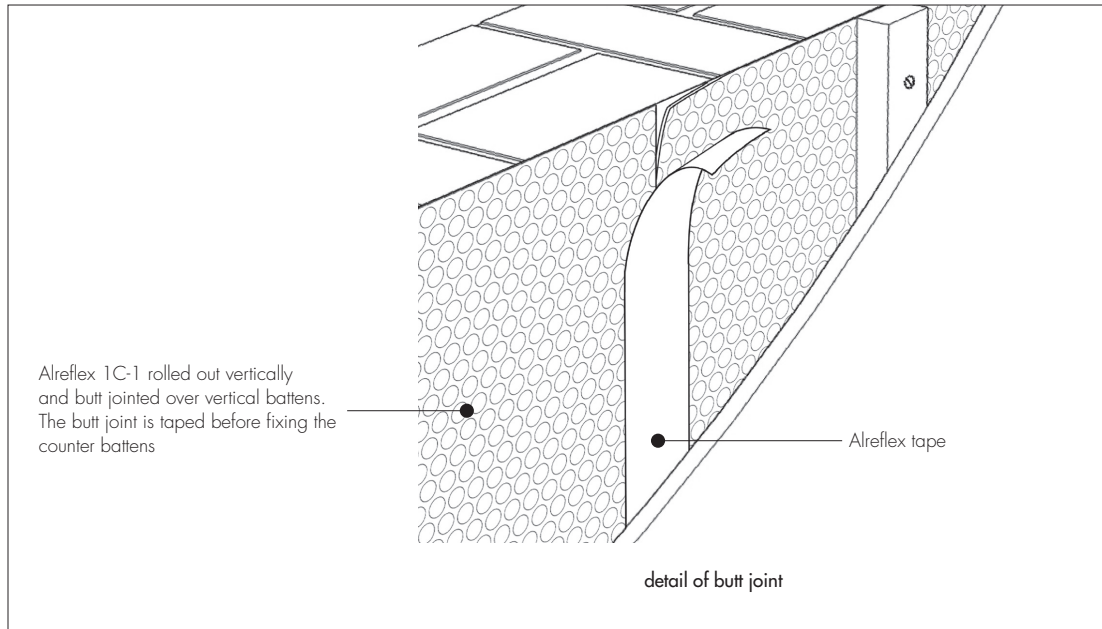
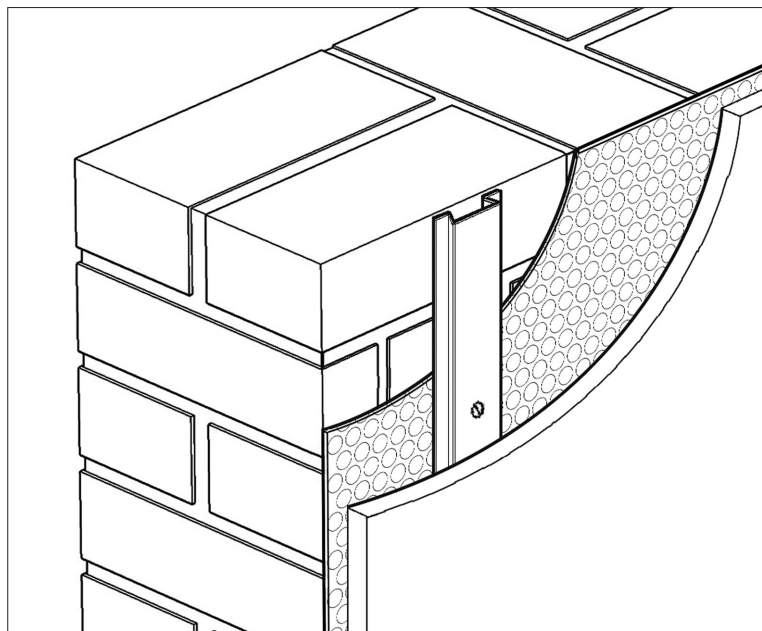

Figure 6 Metal furrings method



## Technical Investigations

### 14 Tests

Results of test data carried out on Alreflex 1L-1 Dry Lining Wall Insulation were assessed to determine:

- dimensional accuracy
- behaviour in relation to fire
- resistance to tearing
- emissivity
- thermal resistance
- condensation risk
- performance in fire
- durability.

## 15 Investigations

15.1 The manufacturing process was evaluated, including the methods adopted for quality control, and details obtained of the quality and composition of the materials used.

15.2 A condensation risk analysis was carried out.

15.3 A series of U value calculations was carried out.

15.4 Sites were visited to assess the practicability of installation.

## Bibliography

- BS 476-6 : 1997 *Fire tests on building materials and structures — Method of test to determine the classification of the surface spread of flame*
- BS 5250 : 2011 *Code of practice for control of condensation in buildings*
- BS 8000-3 : 2001 *Workmanship on building sites — Code of practice for masonry*
- BS 8212 : 1995 *Code of practice for dry lining and partitioning using gypsum plasterboard*
- BS EN 520 : 2004 *Gypsum plasterboards — Definitions, requirements and test methods*
- BS EN 1996-1-1 : 2005 *Eurocode 6 : Design of masonry structures — General rules for reinforced and unreinforced masonry structures*
- NA to BS EN 1996-1-1 : 2005 UK National Annex to *Eurocode 6 : Design of masonry structures — General rules for reinforced and unreinforced masonry structures*
- BS EN 1996-1-2 : 2005 *Eurocode 6 : Design of masonry structures — General rules — Structural fire design*
- NA to BS EN 1996-1-2 : 2005 UK National Annex to *Eurocode 6 : Design of masonry structures — General rules — Structural fire design*
- BS EN 1996-2 : 2006 *Eurocode 6 : Design of masonry structures — Design considerations, selection of materials and execution of masonry*
- NA to BS EN 1996-2 : 2006 UK National Annex to *Eurocode 6 : Design of masonry structures — Design considerations, selection of materials and execution of masonry*
- BS EN 1996-3 : 2006 *Eurocode 6 : Design of masonry structures : Simplified calculation methods for unreinforced masonry structures*
- NA to BS EN 1996-3 : 2006 UK National Annex to *Eurocode 6 : Design of masonry structures : Simplified calculation methods for unreinforced masonry structures*
- BS EN ISO 6946 : 2007 *Building components and building elements — Thermal resistance and thermal transmittance — Calculation method*
- BS EN ISO 9001 : 2008 *Quality management systems — Requirements*
- BRE Information Paper IP 1/06 *Assessing the effects of thermal bridging at junctions and around openings*
- BRE Report (BR 262 : 2002) *Thermal insulation: avoiding risks*
- BRE Report (BR 443 : 2006) *Conventions for U-value calculations*

## 16 Conditions

16.1 This Certificate:

- relates only to the product/system that is named and described on the front page
- is issued only to the company, firm, organisation or person named on the front page — no other company, firm, organisation or person may hold or claim that this Certificate has been issued to them
- is valid only within the UK
- has to be read, considered and used as a whole document — it may be misleading and will be incomplete to be selective
- is copyright of the BBA
- is subject to English Law.

16.2 Publications, documents, specifications, legislation, regulations, standards and the like referenced in this Certificate are those that were current and/or deemed relevant by the BBA at the date of issue or reissue of this Certificate.

16.3 This Certificate will remain valid for an unlimited period provided that the product/system and its manufacture and/or fabrication, including all related and relevant parts and processes thereof:

- are maintained at or above the levels which have been assessed and found to be satisfactory by the BBA
- continue to be checked as and when deemed appropriate by the BBA under arrangements that it will determine
- are reviewed by the BBA as and when it considers appropriate.

16.4 The BBA has used due skill, care and diligence in preparing this Certificate, but no warranty is provided.

16.5 In issuing this Certificate, the BBA is not responsible and is excluded from any liability to any company, firm, organisation or person, for any matters arising directly or indirectly from:

- the presence or absence of any patent, intellectual property or similar rights subsisting in the product/system or any other product/system
- the right of the Certificate holder to manufacture, supply, install, maintain or market the product/system
- actual installations of the product/system, including their nature, design, methods, performance, workmanship and maintenance
- any works and constructions in which the product/system is installed, including their nature, design, methods, performance, workmanship and maintenance
- any loss or damage, including personal injury, howsoever caused by the product/system, including its manufacture, supply, installation, use, maintenance and removal
- any claims by the manufacturer relating to CE marking.

16.6 Any information relating to the manufacture, supply, installation, use, maintenance and removal of this product/system which is contained or referred to in this Certificate is the minimum required to be met when the product/system is manufactured, supplied, installed, used, maintained and removed. It does not purport in any way to restate the requirements of the Health and Safety at Work etc. Act 1974, or of any other statutory, common law or other duty which may exist at the date of issue or reissue of this Certificate; nor is conformity with such information to be taken as satisfying the requirements of the 1974 Act or of any statutory, common law or other duty of care.